

Electric Drilling Unit – Model Number Designation

Example - Heavy Duty 3kw (4HP)

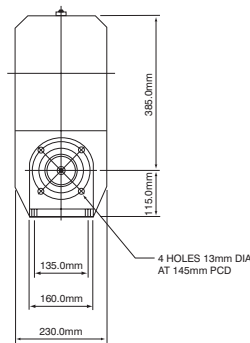
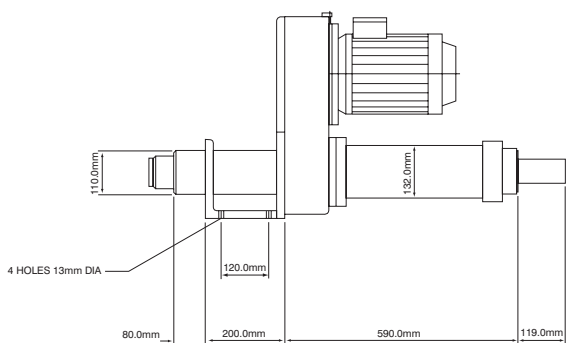
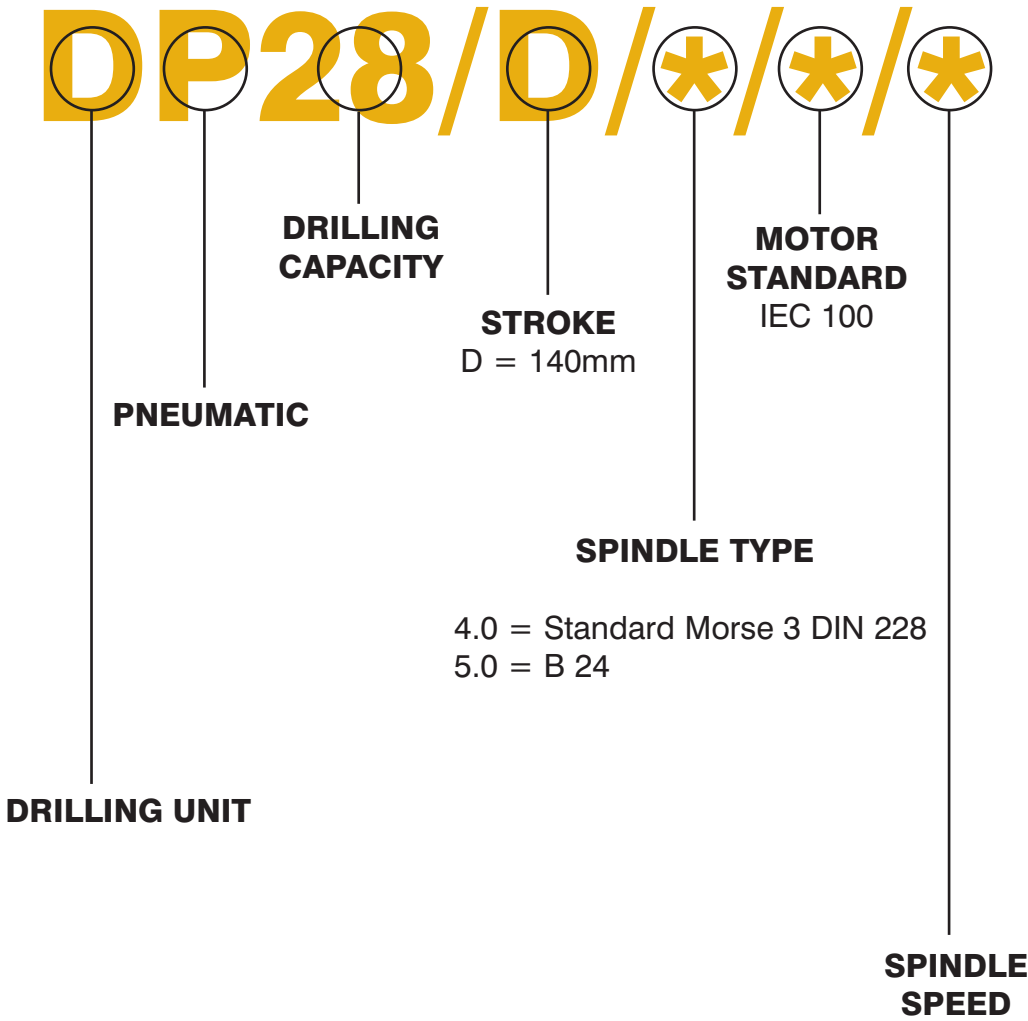

1R =	70
2R =	106
3R =	155
4R =	210
5R =	300
6 =	460
7 =	710
8 =	985
9 =	1420
10 =	1990
11 =	2870

1mm = 0.03937 inches