

# Electric Drilling Unit – Model Number Designation

Example - Heavy Duty 0.75kw (1HP)

**DP18/C/\*/\*/\*S**

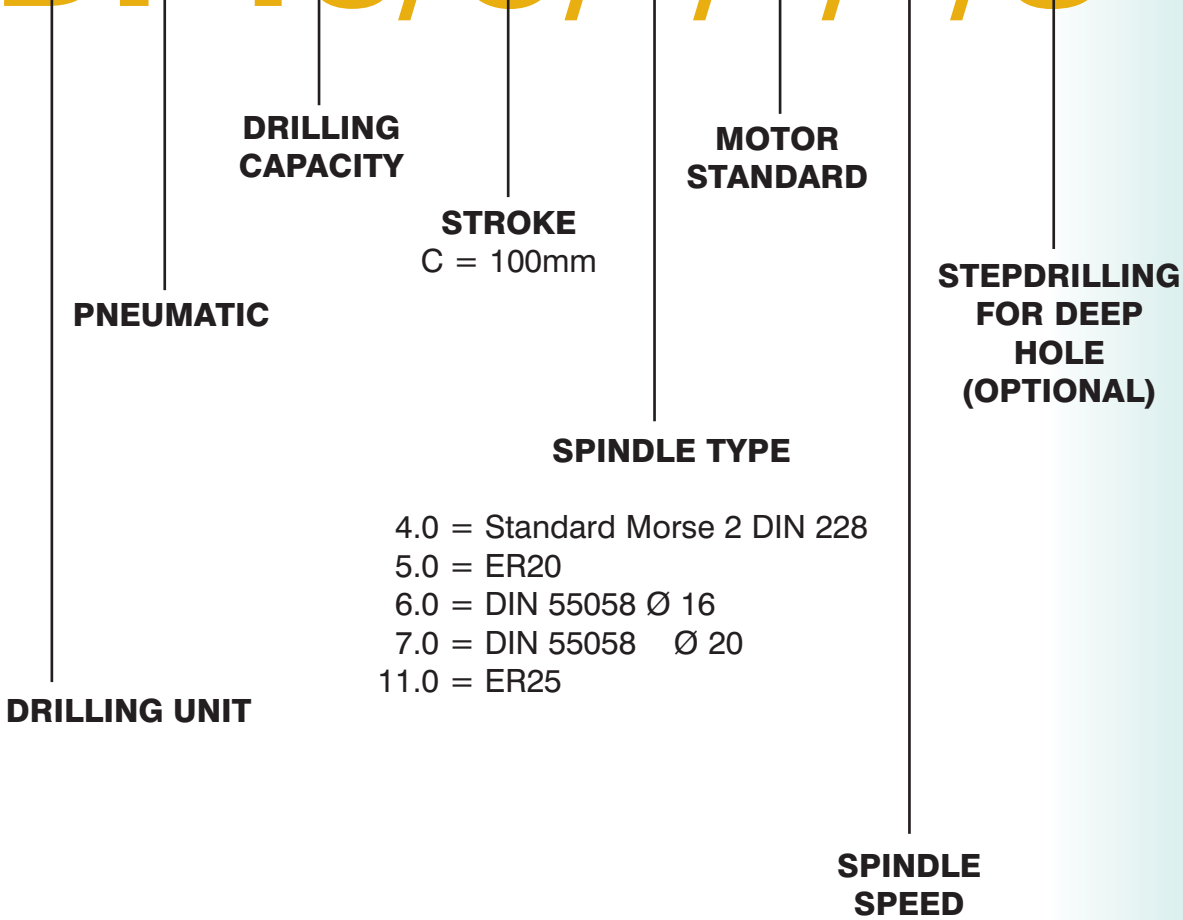

- 4.0 = Standard Morse 2 DIN 228
- 5.0 = ER20
- 6.0 = DIN 55058 Ø 16
- 7.0 = DIN 55058 Ø 20
- 11.0 = ER25

- 1R = 130
- 2R = 160
- 3R = 200
- 4 = 340
- 5 = 530
- 6 = 700
- 8 = 610
- 9 = 1000
- 10 = 1500
- 11 = 1200
- 12 = 2000
- 13 = 3000

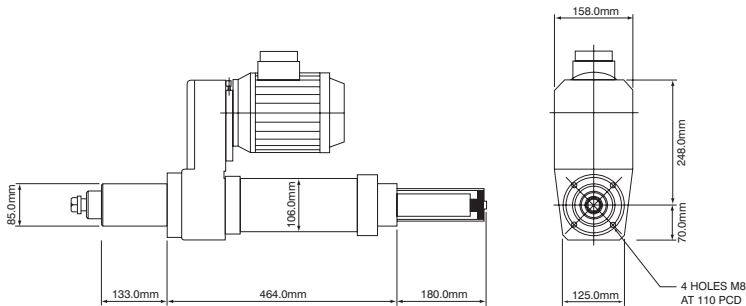

1mm = 0.03937 inches